

Application

The Series VBA is a new innovating coldplate unit for applications that require higher thermal performance. VBA coldplates are especially used for IGCT's/GTO's or IGBT Modules.

General Characteristics

Vacuum brazing is a manufacturing process that offers exceptional design versatility by which to fabricate coldplates with superior, optimized cooling performance.

Type	VBA 55	VBA 85	VBA 100	VBA 125	VBA 155
A	55	85	105	125	155
B	70	100	120	140	170
C	70	100	120	140	170
D	245	26	26	26	26
E	265	72	92	112	142

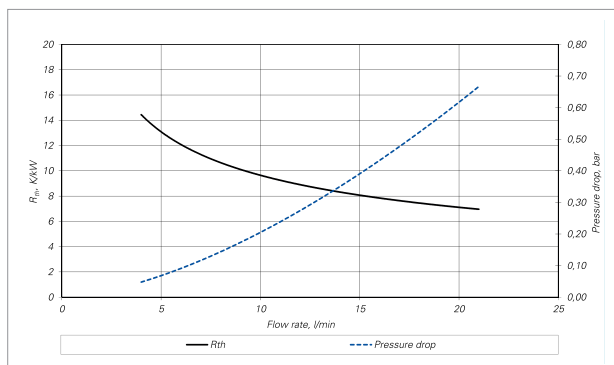

Description

- No. of modules: 2
- Module size: Ø55 [mm]
- Power dissipation: 500 [W/modul]
- Thermocouple: Type K
- Fluid type: Fluid inlet temperature: 50[°C]

Drawings

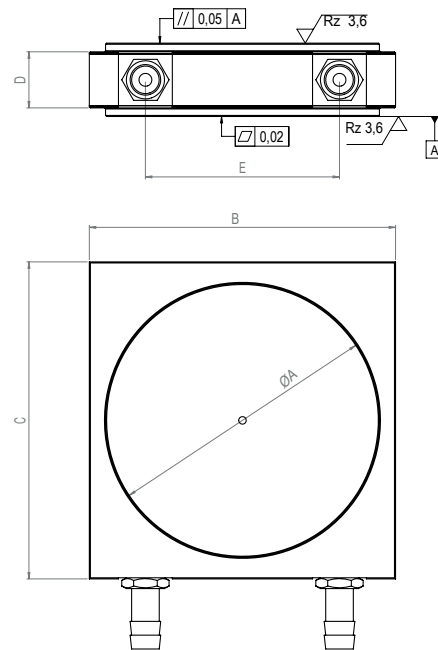

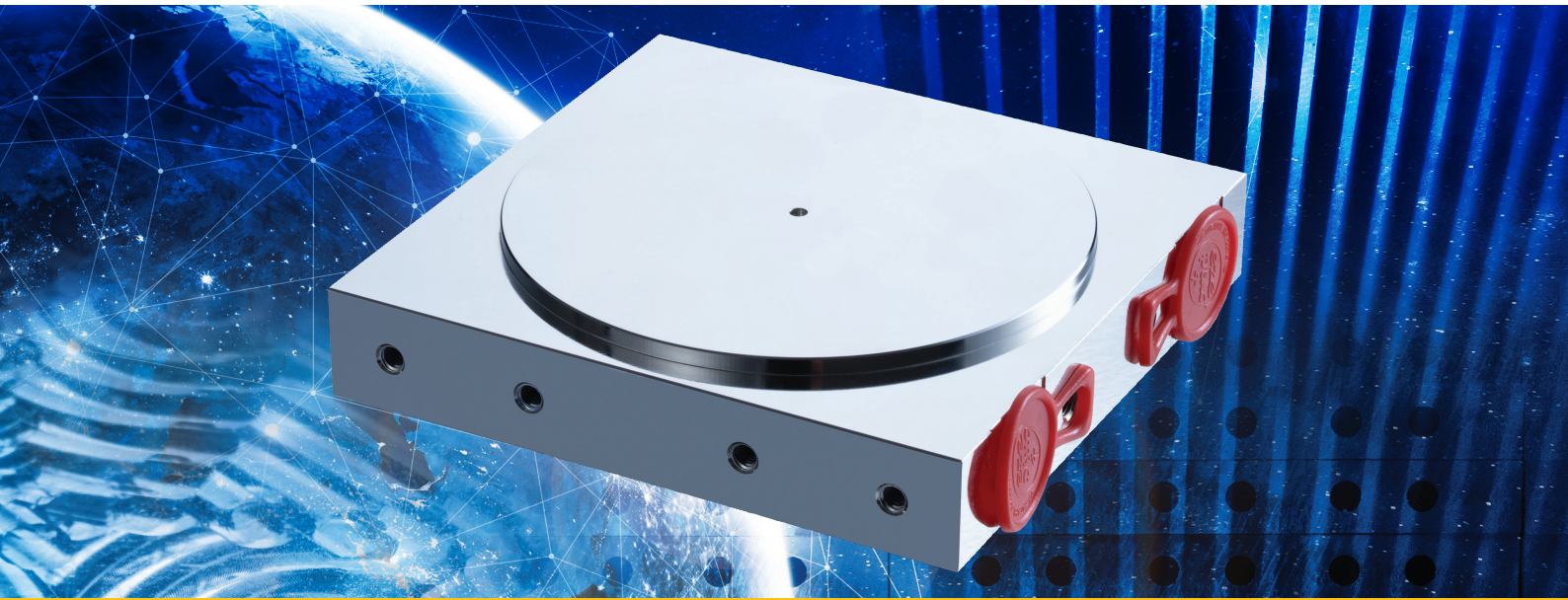

General informations

Vacuum brazing is a manufacturing process that offers exceptional design versatility by which to fabricate cold plates with superior, optimized cooling performance. Channel configurations can be precisely milled into either aluminum or copper plates with strategic positioning in the most demanding heattransfer zones. The size of the channels can also be designed such that the Reynolds number is optimized to provide the best thermal performance for the required flow rate and pressure drop constraints. As well, obstacles such as component mounting holes can easily be designed around without having to sacrifice any cooling performance. The base plate with the machined channel configuration is then covered with a plated cover plate.

The plating is applied on the one side with a thin layer of aluminum alloy (in the case of aluminum brazing) that has a slightly lower melting point than the aluminum cover and base plates. With the plated side sandwiched between the cover and base plates, the assembly is then heated in a vacuum brazing furnace at a temperature in the range of 580 to 600°C which melts the thin layer of aluminum alloy and generates a brazed joint between the cover and base plates. This type of braze bond then produces an extremely reliable and secure joint between the cover and base plates.

Fully automated vacuum braze furnaces built to Miba's specifications braze cooling plate assemblies to pressure tight, stress and vibration resistant coldplates with maximum durability and reliability. In-house designs accompanied by complete machining and testing facilities permit a wide variety of cooling plate solutions to meet our customer's specific needs. The vacuum brazing process ensures trouble free operation even under very challenging operating conditions. With our combination of experience, knowledge and commitment, our team of engineers will design the cooling plate solution to meet your specific performance, space and cost requirements.

Advantages of Vacuum brazed Coldplates

- Optimum design of the cooling path based on the layout of the semiconductors
- Lowest possible thermal resistances
- Leak free, high strength and high mechanical load carrying capacity with burst pressures up to 1150 psi
- No structural changes in the material
- Clean parts without residual flux
- High reliability, durability and life cycle
- Low distortion due to uniform heating and cooling during brazing

Drawings

